



JCB MINI EXCAVATORS | 803 PLUS & 803 SUPER



MAX. ENGINE POWER

23.9kW (32hp)

MAX. DIG DEPTH:

2.78 metres (9ft 1in)

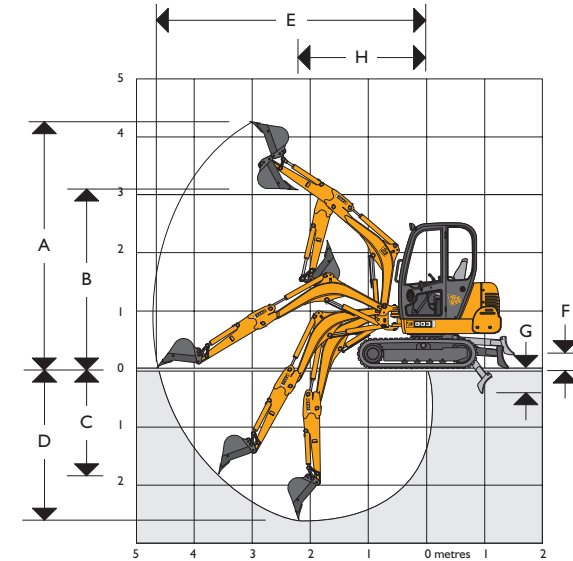
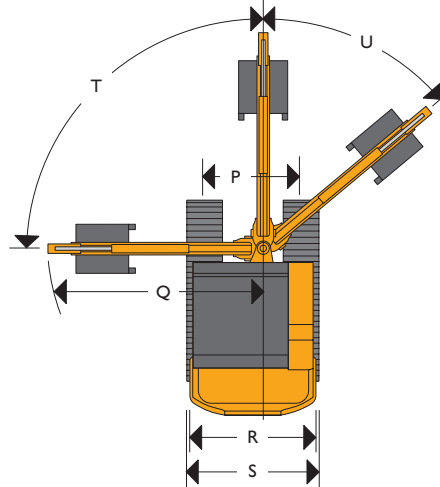
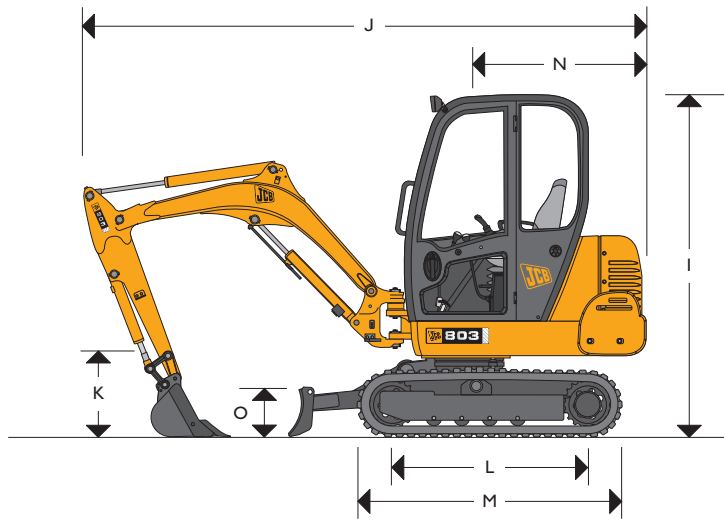

PERFORMANCE DIMENSIONS

Machine model		803 PLUS	803 SUPER
Dipper size	mm	1400	1400
A Max dig height	mm	4361	4361
B Max dump height	mm	3202	3202
C Max vertical dig depth	mm	2137	2137
D Max dig depth-dozer up	mm	2778	2778
Max dig depth-dozer down (L. Dozer)	mm	3015 (3050)	3015 (3050)
E Max reach (ground level)	mm	4753	4753
Bucket rotation	degrees	186°	186°
F Dozer cut above ground (L.Dozer)	mm	233 (307)	233 (307)
G Dozer cut below ground (L.Dozer)	mm	483 (696)	483 (696)
H Min. slew radius	mm	2184	2184
I Overall Height (transport position)	mm	2430	2430
J Overall Length (transport position)	mm	4335	4335
K Kingpost clearance	mm	560	560

PERFORMANCE DIMENSIONS

Machine model		803 PLUS	803 SUPER
L Sprocket idler centres (Rubber)	mm	1585	1585
M Undercarriage length (Rubber)	mm	2030	2030
N Tailswing	mm	1449	1449
O Dozer height	mm	350	350
P Dozer width	mm	1495	1495
Q Min slew radius(no bucket)	mm	2070	2070
R Superstructure width	mm	1410	1410
S Width over tracks	mm	1450	1450
T Boom swing left (limit stop installed)	degrees	90° 70°	90° 70°
U Boom swing right	degrees	50°	50°
Max Bucket tearout (SAE J1179)	Kgf	2121	2193
Max dipper tearout (SAE J1179)	Kgf	1734	1873
Travel speeds 1st Gear	kph	2	2
Travel speeds 2nd Gear	kph	3.6	3.6
Drawbar pull	Kgf	2450	2646
Slew speed	rpm	9.5	9.5



ENGINE

3 cylinder: 403-15, 4 stroke, water cooled diesel engine.

Machine model		803 PLUS/SUPER
Model		403-15
Gross power @ 2200rpm	kW (hp)	20.7 (27.76)
Net power @ 2200rpm	kW (hp)	19.8 (26.55)
Gross torque @ 2000rpm	Nm	96
Net torque @ 2000rpm	Nm	92
Displacement		1496
Starter motor	volt/kW	12/1.2
Battery	volt/amps	12/75
Alternator	amps	55

Fuel injection system: Bosch type in-line integral fuel injection pump. Protected by separate filter and sedimenter.

Manual override on lift pump

UNDERCARRIAGE

Machine model		803 PLUS/SUPER
No. of bottom rollers		4
Track width	mm	350/300
Ground pressure	kg/cm ²	0.29
Ground clearance	mm	320
Track tensioning		Grease

HYDRAULIC SYSTEM

Machine model		803 PLUS	803 SUPER
Pump		Triple Section Gear	1 variable (2 ports)/1 Gear
Nominal output	lpm	29/29/19	29/29/19
Excavator/track main relief	bar	190	207
Slew main relief	bar	172	172
Auxiliary hydraulic flow		57	57
Hydraulic motors		Piston	Piston

SERVICE CAPACITIES

Machine model		803 PLUS/SUPER
Water system capacity	litres	8
Fuel tank capacity	litres	48
Engine oil capacity	litres	5
Hydraulic system capacity	litres	70
Hydraulic tank capacity	litres	48

MACHINE WEIGHTS

Machine model		803 PLUS/SUPER
Operating weight with 1660mm dipper	kg (lb)	3044 (6710)
With 1400mm dipper	kg (lb)	- 12 (- 26)
With 1100mm dipper	kg (lb)	- 18 (- 40)
With steel tracks	kg (lb)	+80.5 (+177)
With long dozer	kg (lb)	+ 15 (+33)

Note: operating weight to ISO 6016 including cab, rubber tracks, short dozer, 610mm bucket, full tanks and 75kg operator.

EEC NOISE LEVELS (95/27/EC DYNAMIC)

Machine model		803 PLUS	803 SUPER
Cab internal	dB (LpA)	78	82
Cab external	dB (LwA)	96	96
Canopy internal	dB (LpA)	79	77
Canopy external	dB (LwA)	96	96

